



Straightaway 600A

Top hung sliding hardware for interior aluminium or timber doors up to 600kg.

Features

- Strong aluminium track
- Quality proven hardware
- Concealed guiding
- Ideal for offices, hospitals, hotels, shopping centres

Specifications

- Max door mass: 600kg
- Max door height: 4000mm
- Max door width: 3000mm
- Door thickness: 44mm

The area of a single sliding leaf should be related to all other factors.

Brought to you by

GHI
ARCHITECTURAL SOLUTIONS

Components

- A600A side or soffit fixing brackets
- 600TA aluminium top track
- 600TO take-out piece
- 600TF (top fix) or 600AS (apron fix) hanger
- 600ES track stop
- 19A aluminium guide channel
- 40T/19N twin bottom nylon guide
- 503NA/GA flush pull handle

Note

- All fittings available in stainless steel for coastal applications.
- Various finishes available.

info@ghi.co.za | www.ghi.co.za

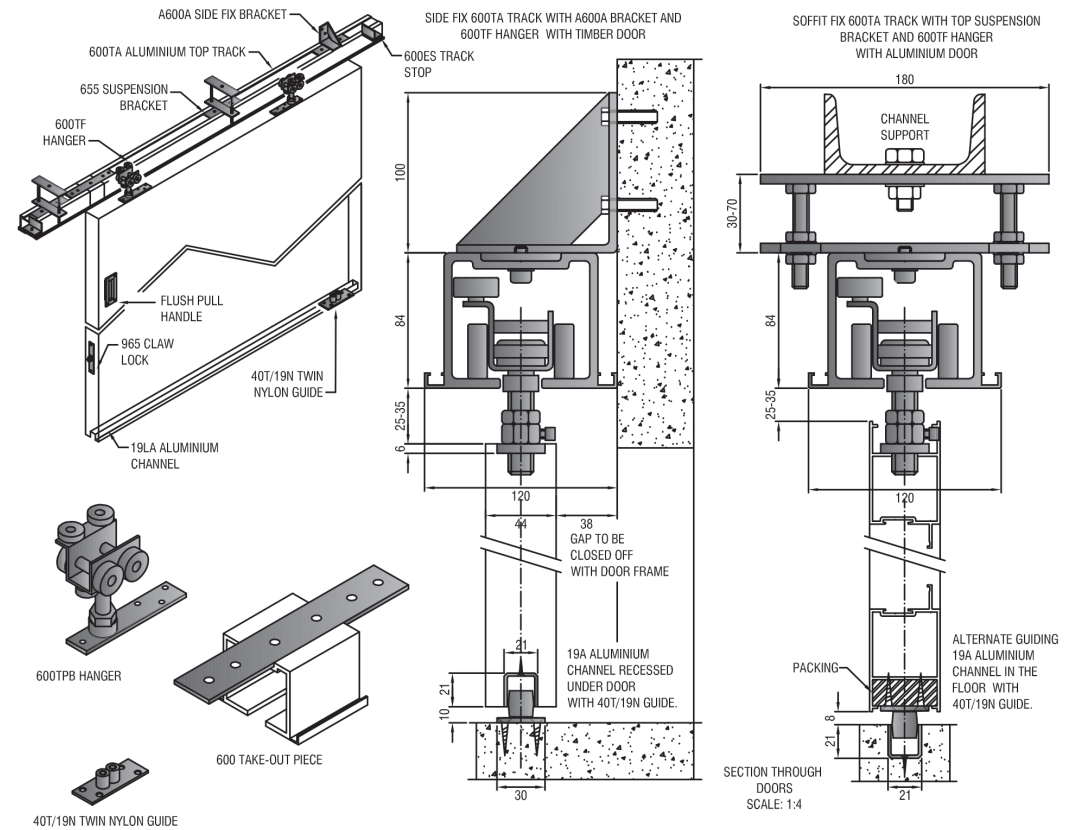

Mechanism



Hillaldam
SLIDING DOOR SYSTEMS

Straight Sliding Door Systems

Domestic, Commercial, Shop Fitting, Hospital, Industrial